



SmartMod

+/-10V Analog Input Module

HE359ADC120 / HE359ADC220
16-Bit Resolution



1 SPECIFICATIONS

	ADC120	ADC220		ADC120	ADC220
Number of Channels	4	8	Conversion Time (PLC Update Rate)	Determined by Communications w/OCS	
Input Ranges	Up to +/-20mA Input		Terminal Type	Screw Type, Removable	
Resolution	16-Bit		Storage Temp.	-40° to 85° Celsius	
Input Impedance	<50 Ohms		Operating Temp.	-10° to 60° Celsius	
Linearity	+/-0.1%		Relative Humidity	5 to 90% Non-condensing	
External Power Supply Voltage	10-30Vdc		Dimensions WxHxD	17.5mm x 100mm x 120mm 0.69" x 3.94" x 4.72"	
Required Power (Steady State)	30mA @ 24Vdc, typical		Weight	150g (6 oz.)	
Required Power (Inrush)	Negligible		Communications	Modbus/RTU (binary) RS-485 half duplex	
Isolation	2000Vac for 60 seconds (Input/Power & Input/Comms)		Default Comms. Parameters	38400 baud, N, 8, 1, no h/s Default Modbus ID 1	
CE & UL Compliance	See Compliance Table at http://www.heapg.com/Support/compliance.htm				

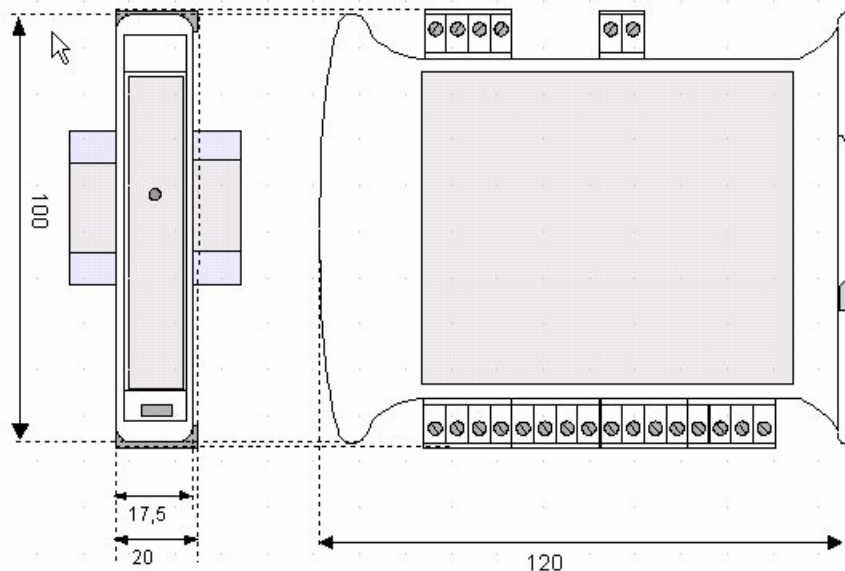

Dimensions in inches are 0.69"W x 3.95"H x 4.72"D
Note: Number of I/O terminal connections vary from model to model

2 WIRING – I/O

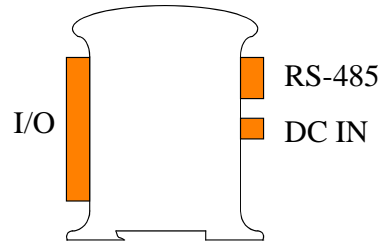
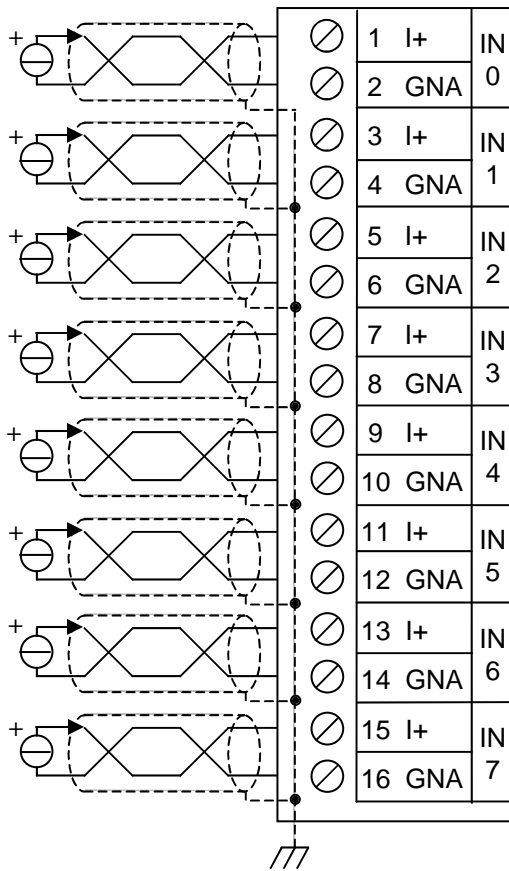

Pin #	ADC120	ADC220
1	INPUT 0+	INPUT 0+
2	ANALOG COMMON	ANALOG COMMON
3	INPUT 1+	INPUT 1+
4	ANALOG COMMON	ANALOG COMMON
5	INPUT 2+	INPUT 2+
6	ANALOG COMMON	ANALOG COMMON
7	INPUT 3+	INPUT 3+
8	ANALOG COMMON	ANALOG COMMON
9	Only Terminals 1 through 8 are present on the ADC120 model	INPUT 4+
10		ANALOG COMMON
11		INPUT 5+
12		ANALOG COMMON
13		INPUT 6+
14		ANALOG COMMON
15		INPUT 7+
16		ANALOG COMMON

WIRING – RS-485

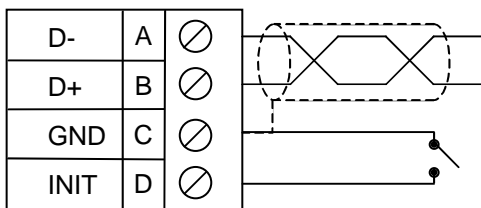

WIRING – DC IN

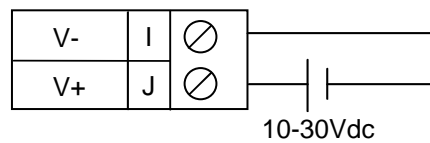

Notes:

Both ends of the RS-485 network should be terminated with a 100 Ohms, 1/4W, 1% resistor. Many OCS controllers feature dip switches or jumpers which enable appropriate termination if the OCS is located on a network end..

Init Default Setup:

1. Install jumper between INIT and GND terminals of the RS-485 port.
2. Apply power to Smartmod unit.
3. Read parameter words to see current parameters.
4. Write changes if necessary.

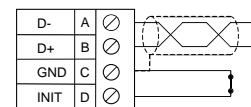

The INIT Default RS485 Settings Are:

Modbus ID = 1
 Baud rate = 9600
 Parity = None
 Stop Bits = 1

3 CONFIGURATION DATA

SmartMod Configuration settings are mapped into Modbus Register space. This configuration data may be modified with any Modbus/RTU Master device. For convenience, Horner APG has developed a variety of Cscape application files which allow an OCS (Xle, NX, LX, QX) to act as a SmartMod configurator. Initial configuration of SmartMod module should be done on an individual basis, since all modules come from the factory with a default Modbus ID of 1. Once each module on the network has its own unique Modbus ID, further configuration adjustments can be made with the entire network powered.

All configuration parameters listed below (except 40012 Channel Enable) are stored in EPROM. That means they should not be constantly rewritten.

Configuration Parameters – Registers 40001 through 40013				
Modbus Register	Description	Min	Max	Default
40001-40005	Reserved			
40006	Communications Parameters	See Table		38.4kbaud, N, 8, 1, RTU Mode
40007	Modbus ID	1	255	1
40008	Rx/Tx Delay (in 2mS steps)	0	255	0mS
40009	Watchdog Timer (in 0.5s steps)	0	255	10 (5s)
40010	Modbus Coil Data	Not Configuration Data – See I/O Data		
40011	Input Type	5	5	6 (+/-20mA)
40012	Channel Enable	See Table		255 (Channels 1-8 enabled)
40013	Reserved			

Register 40006 (Communications Parameters) Bit Definition							
Bits 7-15	Bit 6	Bit 5	Bit 4	Bit 3	Bit 2	Bit 1	Bit 0
Unused	Mode	Parity		Data Bits	Baud Rate		
	0 = ASCII Mode	Value	Meaning	0 = 7 Data Bits	Value	Meaning	
		0	Mark		0	1200 baud	
	1 = RTU Mode	1	Even	1 = 8 Data Bits	1	2400 baud	
		2	Odd		2	4800 baud	
		3	Space		3	9600 baud	
					4	19200 baud	
					5-7	38400 baud	

Register 40012 (Channel Enable) Bit Definition								
Bit 8-15	Bits 7	Bit 6	Bit 5	Bit 4	Bit 3	Bit 2	Bit 1	Bit 0
Unused	Input 7	Input 6	Input 5	Input 4	Input 3	Input 2	Input 1	Input 0
	0 = Disable Input							
	1 = Enable Input							

4 INPUT / OUTPUT DATA

SmartMod Analog I/O utilizes both Modbus Registers (40001-40030) and Coils (1-11). It is possible to access all data using Registers only, because the Coils can be accessed through Register 40010.

The following tables lists all Modbus I/O data available.

I/O Register Data (Registers 40014-40022)					
Modbus Register	Description	Access	Minimum	Maximum	Units
40010	Mirror of Coil Data	Read/Write	n/a	n/a	n/a
40014	Cold Junction Temperature	Read-only	-1000	6000	0.01 degrees C
40015	Input 0	Read-only	-10000	10000	1mV (0.001V)
40016	Input 1	Read-only	-10000	10000	1mV (0.001V)
40017	Input 2	Read-only	-10000	10000	1mV (0.001V)
40018	Input 3	Read-only	-10000	10000	1mV (0.001V)
40019	Input 4	Read-only	-10000	10000	1mV (0.001V)
40020	Input 5	Read-only	-10000	10000	1mV (0.001V)
40021	Input 6	Read-only	-10000	10000	1mV (0.001V)
40022	Input 7	Read-only	-10000	10000	1mV (0.001V)

Modbus Coil	Description	Access
00001	Open Detect Input 0	Read/Write
00002	Open Detect Input 1	Read/Write
00003	Open Detect Input 2	Read/Write
00004	Open Detect Input 3	Read/Write
00005	Open Detect Input 4	Read/Write
00006	Open Detect Input 5	Read/Write
00007	Open Detect Input 6	Read/Write
00008	Open Detect Input 7	Read/Write
00009	Watchdog Enabled	Read/Write
00010	Watchdog Event	Read/Write
00011	Power-up Event	Read/Write

Watchdog Event & Power-up Event Operation

If Coil 9 (Watchdog Enabled) is set, Coil 10 (Watchdog Event) will set if the Watchdog Timeout value is exceeded. The Watchdog Timeout value is set in Register 40009. When set, Coil 10 can be reset by the controller when normal communications resumes.

The Power-up Event (Coil 11) is set every time the power is applied. It can be cleared by the controller if desired.

5 INSTALLATION / SAFETY

Warning: Remove power from the OCS controller, CAN port, and any peripheral equipment connected to this local system before adding or replacing this or any module.

- All applicable codes and standards should be followed in the installation of this product.
- Shielded, twisted-pair wiring should be used for best performance.
- Shields may be terminated at the module terminal strip.
- In severe applications, shields should be tied directly to the ground block within the panel.
- Use the following wire type or equivalent: Belden 8441.

For detailed installation and a [handy checklist](#) that covers panel box layout requirements and minimum clearances, refer to the hardware manual of the controller being used. (See the **Additional References** section in this document.)

When found on the product, the following symbols specify:



Warning: Consult user documentation.



Warning: Electrical Shock Hazard.

6 TECHNICAL SUPPORT

For assistance and manual up-dates, contact Technical Support at the following locations:

Helpdesk: <http://www.horner-apg.com/helpdesk>

North America:
(317) 916-4274
www.heapg.com

Europe:
(+) 353-21-4321-266
www.horner-apg.com

NOTES