



SmartMod Analog Output Module

HE359DAC201
0-10V
14-Bit Resolution



1 SPECIFICATIONS

DAC201		DAC201	
Number of Channels	8	Thermal Drift	100ppm max
Output Ranges	0-10V	Terminal Type	Screw Type, Removable
Resolution	Approximately 14-Bit	Storage Temp.	-40° to 85° Celsius
Load Resistance	Voltage: >5Kohm	Operating Temp.	-10° to 60° Celsius
Output Calibration	Voltage: +/-10mV	Relative Humidity	5 to 95% Non-condensing
External Power Supply Voltage	18-30Vdc	Dimensions WxHxD	17.5mm x 100mm x 120mm 0.69" x 3.94" x 4.72"
Required Power (Steady State)	30mA @ 24Vdc, typical	Weight	150g (6 oz.)
Required Power (Inrush)	Negligible	Communications	Modbus/RTU (binary) RS-485 half duplex
Isolation	2000Vac for 60 seconds (Input/Power & Input/Comms)	Default Comms. Parameters	38400 baud, N, 8, 1, no h/s Default Modbus ID 1
		Supported Modbus Commands (family)	1,2,3,4,5,6,8,15,16
CE & UL Compliance	See Compliance Table at http://www.heapg.com/Support/compliance.htm		

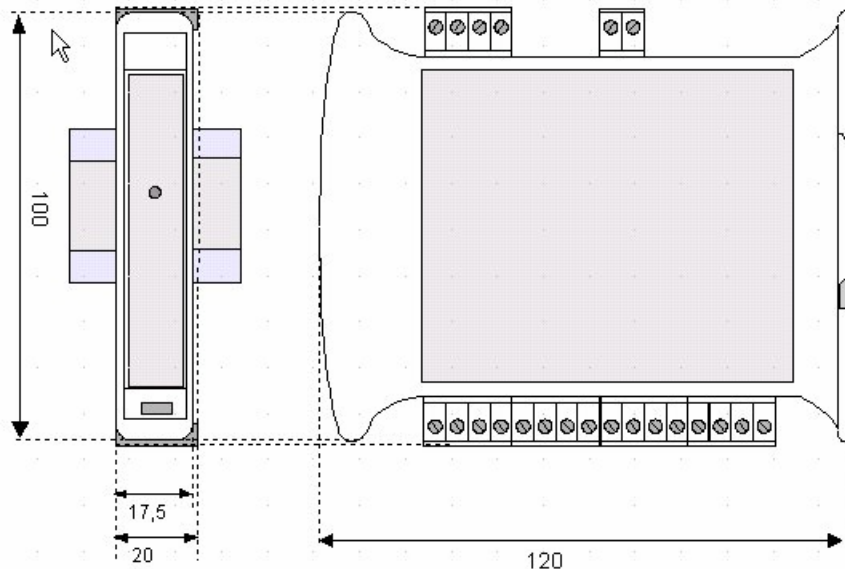

Dimensions in inches are 0.69"W x 3.95"H x 4.72"D
Note: Number of I/O terminal connections vary from model to model

2 WIRING – I/O

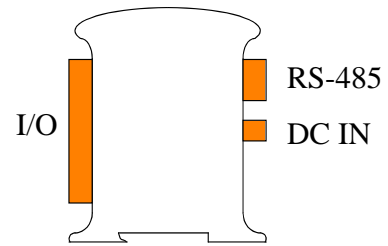
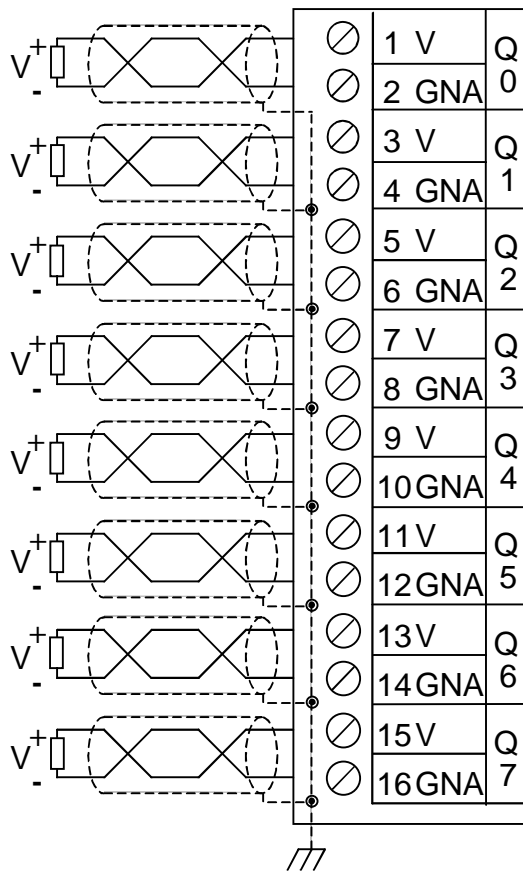

Pin #	DAC201	
1	V	OUT 0
2	GNA	
3	V	OUT 1
4	GNA	
5	V	OUT 2
6	GNA	
7	V	OUT 3
8	GNA	
9	V	OUT 4
10	GNA	
11	V	OUT 5
12	GNA	
13	V	OUT 6
14	GNA	
15	V	OUT 7
16	GNA	

WIRING – RS-485

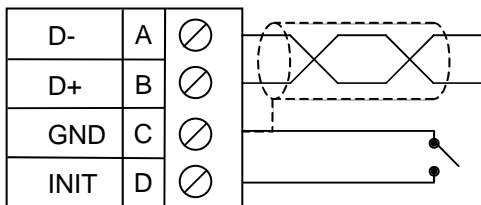

WIRING – DC IN

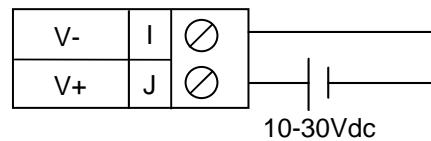

Notes:

Both ends of the RS-485 network should be terminated with a 100ohm, 1/4W, 1% resistor. Many OCS controllers feature dip switches or jumpers which enable appropriate termination if the OCS is located on a network end..

Init Default Setup:

1. Install jumper between INIT and GND terminals of the RS-485 port.
2. Apply power to Smartmod unit.
3. Read parameter words to see current parameters.
4. Write changes if necessary.

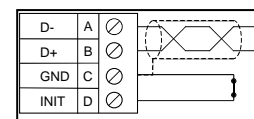

The INIT Default RS485 Settings Are:

Modbus ID = 1
 Baud rate = 9600
 Parity = None
 Stop Bits = 1

3 CONFIGURATION DATA

SmartMod Configuration settings are mapped into Modbus Register space. This configuration data may be modified with any Modbus/RTU Master device. For convenience, Horner APG has developed a variety of Cscape application files which allow an OCS (Xle, NX, LX, QX) to act as a SmartMod configurator. Initial configuration of SmartMod module should be done on an individual basis, since all modules come from the factory with a default Modbus ID of 1. Once each module on the network has its own unique Modbus ID, further configuration adjustments can be made with the entire network powered.

All configuration parameters listed below (except 40012 Channel Enable) are stored in EPROM. That means they should not be constantly rewritten.

Configuration Parameters – Registers 40001 through 40013				
Modbus Register	Description	Min	Max	Default
40001-40005	Reserved			
40006	Communications Parameters	See Table		38.4kbaud, N, 8, 1, RTU Mode
40007	Modbus ID	1	255	1
40008	Rx/Tx Delay (in 2mS steps)	0	255	0mS
40009	Watchdog Timer (in 0.5s steps)	0	255	10 (5s)
40010	Modbus Coil Data	Not Configuration Data – See I/O Data		
40011		Reserved		
40012		Reserved		
40013		Reserved		
40014	Output Type	255	255	255 (All channels Voltage)

Register 40006 (Communications Parameters) Bit Definition							
Bits 7-15	Bit 6	Bit 5	Bit 4	Bit 3	Bit 2	Bit 1	Bit 0
Unused	Mode	Parity		Data Bits	Baud Rate		
	0 = ASCII Mode	Value	Meaning	0 = 7 Data Bits	Value	Meaning	
		0	Mark		0	1200 baud	
	1 = RTU Mode	1	Even	1 = 8 Data Bits	1	2400 baud	
		2	Odd		2	4800 baud	
		3	Space		3	9600 baud	
					4	19200 baud	
					5-7	38400 baud	

4 INPUT / OUTPUT DATA

SmartMod Analog I/O utilizes both Modbus Registers (40001-40030) and Coils (1-11). It is possible to access all data using Registers only, because the Coils can be accessed through Register 40010.

The following tables lists all Modbus I/O data available.

I/O Register Data (Registers 40010-40026)					
Modbus Register	Description	Access	Minimum	Maximum	Units
40010	Mirror of Coil Data	Read/Write	n/a	n/a	n/a
40015	Output 0	Read/Write	0	10000	1mV
40016	Output 1	Read/Write	0	10000	1mV
40017	Output 2	Read/Write	0	10000	1mV
40018	Output 3	Read/Write	0	10000	1mV
40019	Output 4	Read/Write	0	10000	1mV
40020	Output 5	Read/Write	0	10000	1mV
40021	Output 6	Read/Write	0	10000	1mV
40022	Output 7	Read/Write	0	10000	1mV
40023	Default/Safe Value Out 0	Read/Write	0	10000	1mV
40024	Default/Safe Value Out 1	Read/Write	0	10000	1mV
40025	Default/Safe Value Out 2	Read/Write	0	10000	1mV
40026	Default/Safe Value Out 3	Read/Write	0	10000	1mV
40027	Default/Safe Value Out 4	Read/Write	0	10000	1mV
40028	Default/Safe Value Out 5	Read/Write	0	10000	1mV
40029	Default/Safe Value Out 6	Read/Write	0	10000	1mV
40030	Default/Safe Value Out 7	Read/Write	0	10000	1mV

Modbus Coil	Description	Access
00009	Watchdog Enabled	Read/Write
00010	Watchdog Event	Read/Write
00011	Power-up Event	Read/Write

Watchdog Event & Power-up Event Operation

If Coil 9 (Watchdog Enabled) is set, Coil 10 (Watchdog Event) will set if the Watchdog Timeout value is exceeded. The Watchdog Timeout value is set in Register 40009. When set, Coil 10 can be reset by the controller when normal communications resumes.

The Power-up Event (Coil 11) is set every time the power is applied. It can be cleared by the controller if desired.

Modbus Register	Description	Access
40010 bit 0	Watchdog Enabled	Read/Write
40010 bit 1	Watchdog Event	Read/Write
40010 bit 2	Power-up Event	Read/Write

5 INSTALLATION / SAFETY

Warning: Remove power from the OCS controller, CAN port, and any peripheral equipment connected to this local system before adding or replacing this or any module.

- All applicable codes and standards should be followed in the installation of this product.
- Shielded, twisted-pair wiring should be used for best performance.
- Shields may be terminated at the module terminal strip.
- In severe applications, shields should be tied directly to the ground block within the panel.
- Use the following wire type or equivalent: Belden 8441.

For detailed installation and a handy checklist that covers panel box layout requirements and minimum clearances, refer to the hardware manual of the controller you are using. (See the **Additional References** section in this document.)

When found on the product, the following symbols specify:



Warning: Consult user documentation.



Warning: Electrical Shock Hazard.

6 TECHNICAL SUPPORT

Helpdesk: <http://www.horner-apg.com/helpdesk>

For assistance and manual up-dates, contact Technical Support at the following locations:

North America:
(317) 916-4274
www.heapg.com

Europe:
(+) 353-21-4321-266
www.horner-apg.com

NOTES